



Nipper technology | Air shears

Blades for special air shears, single-acting

Blades for special air shears, single-acting



Product notes

- > Blades for cutting synthetic materials, e.g. kevlar, aramid, glass and carbon fiber
- > With the exception of H120SK not suitable for thick cardboard, sheet tin, wire, wood

Technical data

Item no.	Max. opening for cutting [mm]	Effective cutting length [mm]	Max. cutting thickness [mm]		Weight [g]	Air nippers
			Kevlar	Band steel		
H30ME	26	50	1	--	280	GT-H30 GT-HS30
H12ME30K	17	28	0.3	--	56	GT-H12K
H120SK	15	38	--	15x0.5	115	GT-H120K

Dimensions

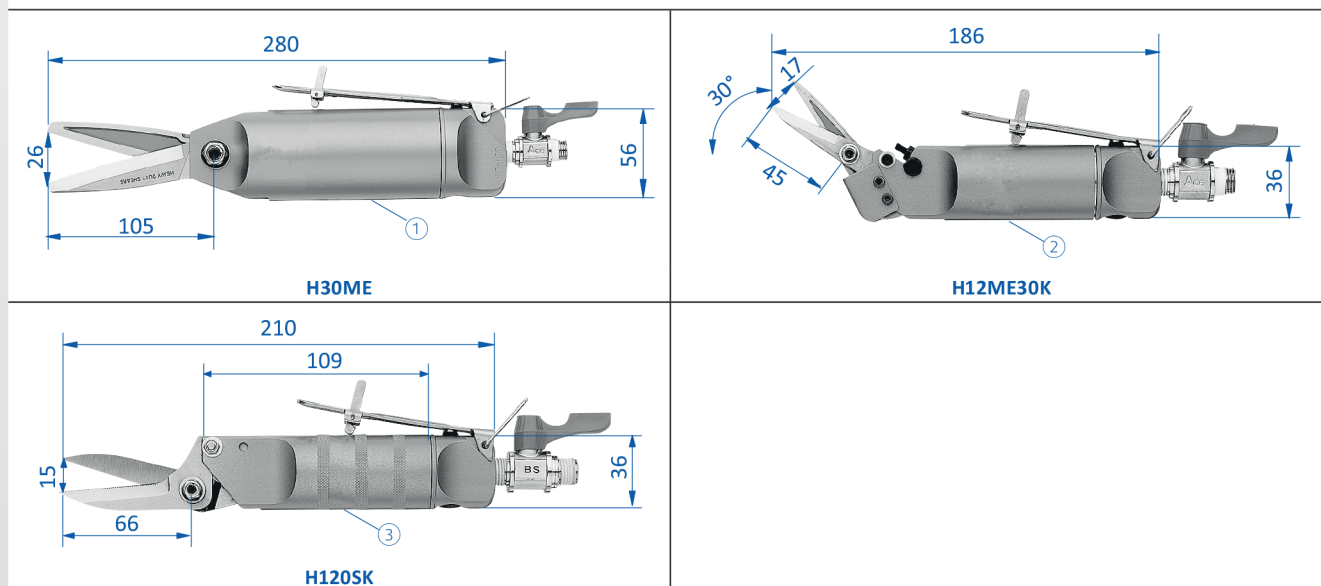

① = Special air shear shown: GT-H30 ② = Special air shear shown: GT-H12K ③ = Special air shear shown: GT-H120K